

THE INFORMATION CONTAINED IN THIS DRAWING IS THE SOLE PROPERTY OF VTE INCORPORATED. ANY REPRODUCTION IN PART OR WHOLE WITHOUT THE WRITTEN PERMISSION OF VTE INCORPORATED IS PROHIBITED. VTE MAKES NO WARRANTY, EXPRESSED OR IMPLIED, AS TO THE SUITABILITY OF A PRODUCT FOR ANY INTENDED USE. THE CUSTOMER SHALL BEAR THE SOLE RESPONSIBILITY OF DETERMINING THE SUITABILITY OF ANY VTE PRODUCT FOR ITS END USE.

LTR.	REVISIONS	DATE	INT.
A	ADDED FULL RADIUS FOR COVER RETAINER POSTS	01-10-07	BRH
B	P/N 3843-002 REPLACED WITH 3843-008	03-28-16	RAS
C	ADDED NEWTON METERS VALUE TO TORQUE SPEC	11-16-17	RAS
D	ADDED FACTORY TORQUE SPEC TO 3874-000	5-23-24	RAS

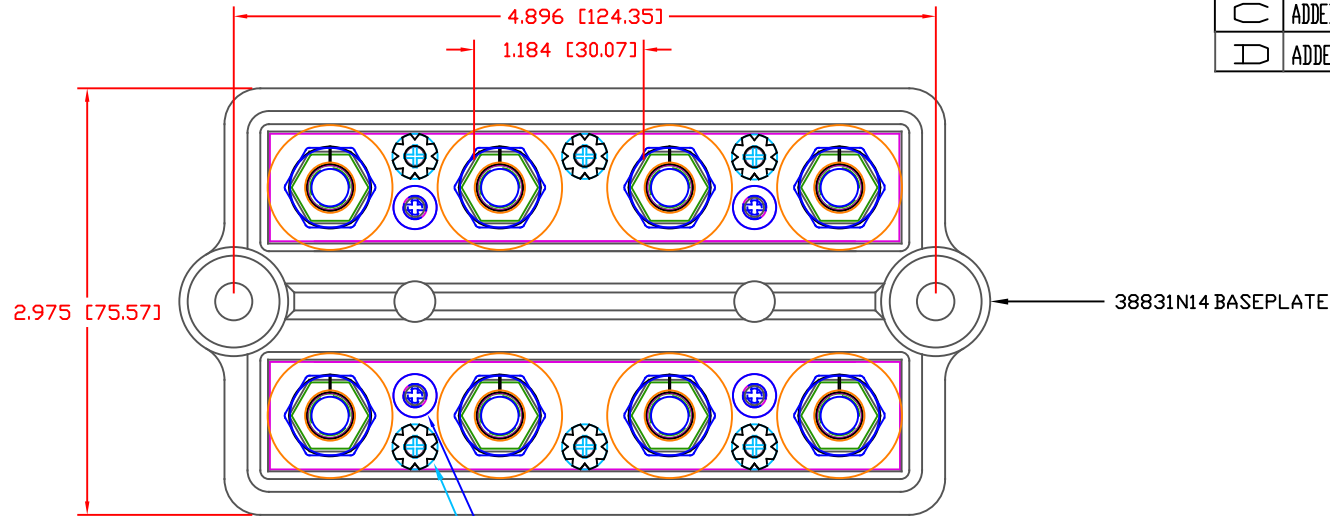

P/N 3870-000 #8-32 x 5/16" SEMS SCREW W/ EXTERNAL TOOTH WASHER (6 PLCS)

P/N 3874-000 #8X 3/8" PHILLIPS FLAT HEAD HIGH-LOW SCREW S.S. (4 PLCS.)
* FACTORY ASSEMBLED TO 10 IN./LBS.

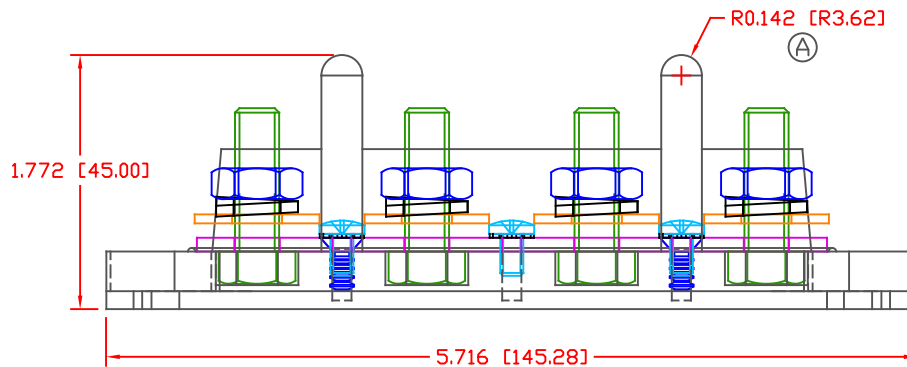

P/N 738N3P05 COVER ASSEMBLY (AVAILABLE SEPARATELY) CONSISTS OF (1) 338N9V COVER AND (2) 324N3V05 COVER RETAINERS

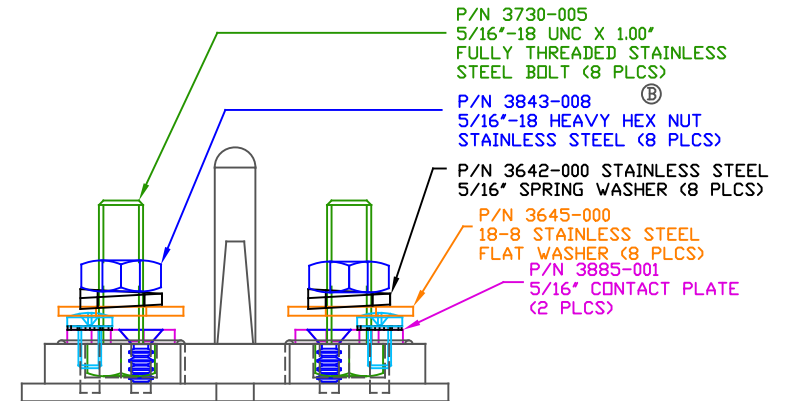

ALL DIMENSIONS GIVEN AS: in [mm]
MOLDED PARTS: ±.030" [±0.8mm]
HARDWARE ITEMS: ±.010" [±0.25mm]

MATERIAL PART NO:
MATERIAL:
VENDOR PART NO:
SPECIFIC GRAVITY:
MELTING TEMP:
U.L. RATING:

1111210514UL
GLASS FILLED NYLON
HYLON N2015 HL BK
1.23
515 F [268 C]
UL 94 HB

MAX RECOMMENDED FASTENER TORQUE: 5/16" STUDS 144 IN./LBS. [16.2 Nm]
(ANTI-SEIZE RECOMMENDED)

MAX RECOMMENDED CURRENT: 250 AMPS TOTAL @ 12 VDC



VTE Incorporated
5437 Robinson Road, P.O. Box 790
Pellston, Michigan 49769
Telephone: 1-800-527-9256, 231-539-8000
FAX: 231-539-0914

REF:	DATE:	DRN BY:	BRH	WEIGHT:
CUSTOMER DIMS	10-24-06	CHK'D BY:	BRH	
TITLE:		5/16" DUAL 4- POINT BUS BAR		
MATERIAL: GLASS FILLED NYLON		PART NO.		
COLOR: BLACK		738831N0N14		
DRG CLASS		REV D		